



A Brand of Heatcraft Refrigeration Products
 2175 West Park Place Boulevard
 Stone Mountain, GA 30087
 800.537.7775
 www.thecoldstandard.com

SWN1500M6C
 Semi-Hermetic
 Water-cooled

Project:	QUOTATION: Water cooled submittals Item No: 7
Location: ,	Submitted by: Tim Blackmore
Customer:	DATE: 8/21/2015
Identity #:	<input checked="" type="checkbox"/> For Record By: _____
Tag:	<input type="checkbox"/> For Approval Date: _____

PHYSICAL & ELECTRICAL DATA

	COMPRESSOR		CONNECTIONS (inches)		RECEIVER CAPACITY (90%)	NET WEIGHT	WATER (FPT)	85°F INLET 15° SST	AMBIENT TEMP
	Model No.	HP	Liquid	Suction					
	3DS3R17M E	15	7/8	1 5/8	125	790	1-1/2	25.6 GPM	95°F

POWER SUPPLY	COMPRESSOR		FAN MOTOR			MCA†		MOP‡		Evap. Fan	Defrost Heater
	Volts / Ph / Hz	RLA	LRA	QTY	HP	FLA	Air	Elec.	Air	Elec.	Amps
208-230/3/60	53.5	275				66.9	120	110	125	25	96

†MCA=Minimum Circuit Ampacity
 ‡MOP = Maximum Overcurrent Protection

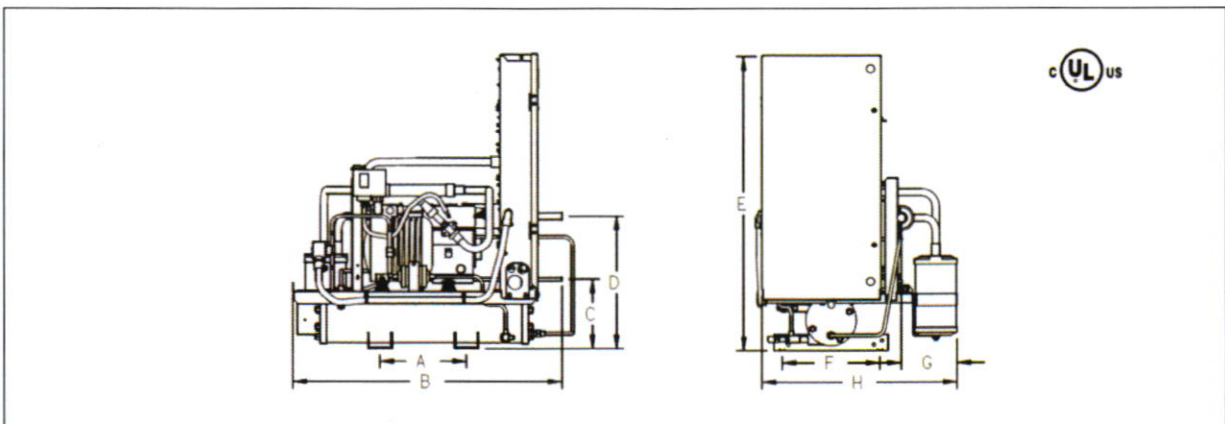

DIMENSIONS (inches)								
A	B	C	D	E	F	G	H	J
24	47	15.625	23.5	43.5	12	18.375	35.375	



A Brand of Heatcraft Refrigeration Products

2175 West Park Place Boulevard
 Stone Mountain, GA 30087
 800.537.7775
 www.thecoldstandard.com

SWN1500M6C

**Semi-Hermetic
 Water-cooled**

Project:	QUOTATION: Water cooled submittals Item No: 7
Location: ,	Submitted by: Tim Blackmore
Customer:	DATE: 8/21/2015
Identity #:	<input checked="" type="checkbox"/> For Record By: _____
Tag:	<input type="checkbox"/> For Approval Date: _____

DIMENSIONS (inches)						
K	L	M	N	P	R	S

CAPACITY (BTUH)						
40 °F SST	35 °F SST	30 °F SST	25 °F SST	20 °F SST	15 °F SST	10 °F SST
198850	179890	161950	146060	131200	117310	0

CAPACITY (BTUH)						
5 °F SST	0 °F SST	-5 °F SST	-10 °F SST	-15 °F SST	-20 °F SST	-25 °F SST
0	0	0	0	0	0	0

CAPACITY (BTUH)						
-30 °F SST	-35 °F SST	-40 °F SST				
0	0	0				

SST = Saturated Suction Temperature

STANDARD FEATURES

- | | |
|---|--|
| <ul style="list-style-type: none"> Construction • Pre-bent tubing • Easy access refrigerant piping • Pressure relief valve • Shell and tube, cleanable condenser • More spacious, pre-painted electrical box • 230 volt control (circuit transformer on 460 volt models) • Single electrical connection location • Shipped with dry nitrogen charge • Heavy duty base plate • Plastic conduit on all wiring runs • Sealed liquid line filter drier with sight glass • Removable electrical box from compressor access from the front • Captive door fasteners | <ul style="list-style-type: none"> Compressor • Semi-hermetic reed and Discus® compressors (3/4-22 HP) • Solid mounted semi-hermetic reed compressors • Spring mounted Discus® compressors with suction and discharge vibration eliminators • Oil pressure switch (where required) • Compressor contactor • Pump down switch • Fixed low pressure switch (adjustable on low temp models) • Fixed high pressure switch |
|---|--|

OPTIONS



A Brand of Heatcraft Refrigeration Products
 2175 West Park Place Boulevard
 Stone Mountain, GA 30087
 800.537.7775
 www.thecoldstandard.com

SWN1500M6C
 Semi-Hermetic
 Water-cooled

Project:	QUOTATION: Water cooled submittals Item No: 7
Location: ,	Submitted by: Tim Blackmore
Customer:	DATE: 8/21/2015
Identity #:	<input checked="" type="checkbox"/> For Record By: _____
Tag:	<input type="checkbox"/> For Approval Date: _____

Mounted Options:

<input checked="" type="checkbox"/> Power Switch: Compressor Circuit Breakers 230	<input checked="" type="checkbox"/> Liquid Filter Drier: Replaceable Core Liquid Filter
<input checked="" type="checkbox"/> Misc:Suction Accumulator	<input checked="" type="checkbox"/> Misc:Dual Pressure Control

Ship Loose Options:

<input checked="" type="checkbox"/> Water Regulating Valve	
--	--

MINIMUM UNIT CLEARANCES

Control Panel access is only requirement.